



JOHN DEERE

JD

CONSTRUCTION EQUIPMENT

CRAWLER LOADERS



MODEL NO.

655C-II 755C-II



C SERIES II

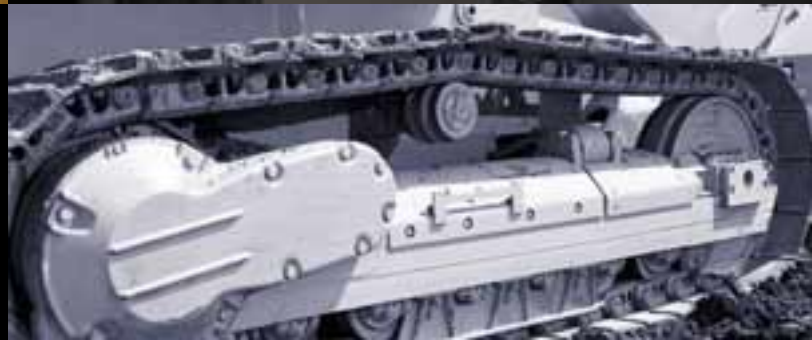



JACK-OF-ALL-TRADES,

Introducing two good machines made great: the 655C and 755C Series II. These new-and-improved loaders feature significant, contractor-driven enhancements including an optimized power management system, more responsive steering, an increased low speed range, and several design changes to enhance operator comfort and convenience. All of this added to an already popular pair of hydrostatic loaders known for impressive breakout force, tipping load capacities, and unsurpassed maneuverability. Read on for details.

JD

CONSTRUCTION EQUIPMENT

CRAWLER LOADERS

MODEL NO.

655C-II 755C-II

MASTER OF MOST

KEY SPECIFICATIONS

	NET HP	OPERATING WEIGHT	STANDARD BUCKET	BREAKOUT FORCE	STATIC TIPPING LOAD
655C-II	130	33,950	2.35 cu. yd.	27,675 lbs.	23,086 lbs.
755C-II	177	46,300	3.14 cu. yd.	37,080 lbs.	30,418 lbs.

DRIVETRAIN

Multi-tasking made easier

We've enhanced hydraulic response for faster boom, bucket cycle times, and improved metering during fine grading.

For more than 25 years, full-featured hydrostatic drivetrains have provided John Deere crawler owners with unsurpassed operating ease and flexibility. Now with our new optimized power management system, you'll feel more power when you need it, and an overall better engine/transmission performance match. That means track motion remains steady while delivering strong pushing power.





Just set maximum desired ground speed and the crawler does the rest. As the loads change, the drivetrain responds, automatically powering up or down to maintain peak engine rpm and efficiency.

Low-speed working range was increased to 4 mph to allow most performance needs to be met in one speed setting for faster cycle times.

Innovative control system keeps these loaders tracking straight in either direction or on level ground or steep slopes. Delivers smooth, predictable turns under full load, too.



Variable ground speeds from standstill to 6.8 mph and full power turn capability give an operator total control — for confidence around critical structures.

Counterrotation is another advantage that's especially helpful for overcoming corner loads and for quickly repositioning the bucket on-the-go. Or use it for space-saving spot turns.

Room with a view

Spacious walk-through air-conditioned cab is standard. Visibility is virtually unobstructed, with a large tinted windshield providing a panoramic view of the work ahead.

Series II enhancements include improved steering response. Pedal steering now better matches pedal movement so steering is smooth and predictable, even on rough terrain.

OPERATOR STATION



Sun in your eyes? Use the roll shade to block it out or to help keep the cab cooler.

Deluxe suspension seat with new wider armrests fully adjusts for daylong support and comfort.

Load-sensing hydraulic system delivers smooth, low-effort, combined function metering and control. Pushbuttons on the top of the handle control return-to-dig and float.

New standard V-pattern control for forward/reverse travel and ground speed is positioned closer to the operator for convenience.

Speed-range control switch and horn button are now more conveniently located to keep the operator focused on the work.



Convenient compartment opens wide, letting you stow away carryons.

Warning lights and gauges in the right-side console keep a vigilant watch on vital operating information.



UNDERCARRIAGE

Steady as you go

Hydrostatic drive motors are mounted externally where they're well-protected, yet readily accessible should servicing be necessary.

Heavy-duty final drives are integrated into the track roller frames with the hydraulic drive motors.

Cast-steel-alloy segmented bolt-on sprockets are easy to remove and replace.

The C-Series-II Loaders' oscillating track frames have a unique cushioned front pivot shaft that absorbs shock loads and greatly enhances the ride, for smooth moves and good grading ability.

Standard equipped with wider pads and longer track frames than most other crawler loaders, the 655C-II and 755C-II's tipping load capacities are impressive, too.

So go ahead — load up their buckets. And experience for yourself how their cushioned track frames, generous track on the ground, and hydrostatic drive system improve comfort and ability.

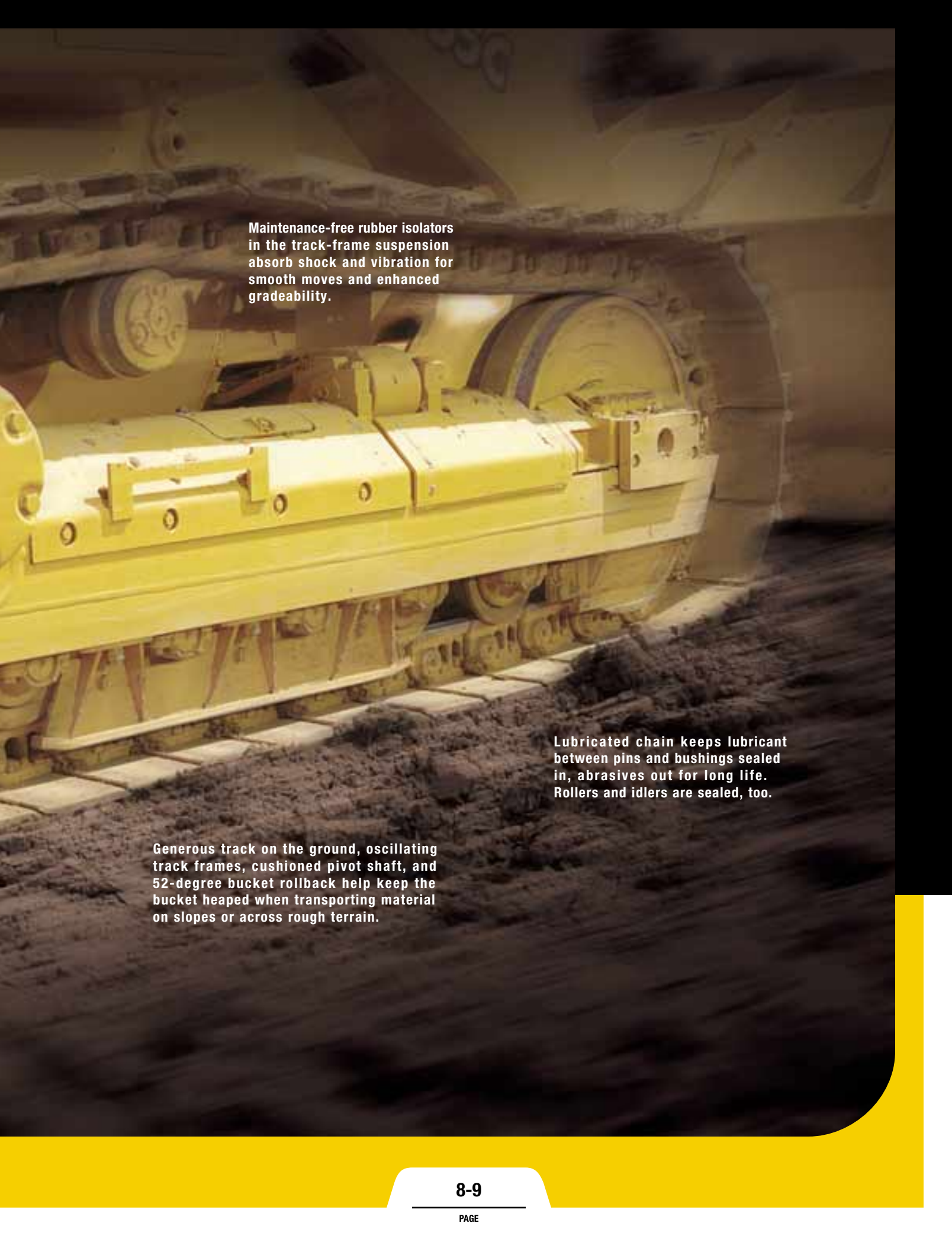

Maintenance-free rubber isolators in the track-frame suspension absorb shock and vibration for smooth moves and enhanced gradeability.

Lubricated chain keeps lubricant between pins and bushings sealed in, abrasives out for long life. Rollers and idlers are sealed, too.

Generous track on the ground, oscillating track frames, cushioned pivot shaft, and 52-degree bucket rollback help keep the bucket heaped when transporting material on slopes or across rough terrain.

As maintenance free as a crawler can be



Wet-sleeve engines with gear-driven water pumps. Lifetime-lubricated bucket pins. Weekly loader lube points. These crawlers are literally loaded with features that minimize maintenance.

Daily checks are accomplished on the same side. Even periodic service points are conveniently grouped, with many protected behind lockable easy-access doors that swing open wide — to simplify fluid and filter checks and changes.

Other thoughtful details include an easy-to-clean undercarriage, remote drive system test ports, and extended service intervals, to list just a few.

Perhaps best of all, each C Series II Loader is backed by a variety of services and product support programs based on our fix-before-fail approach. All of which help you keep costs down and maximize profits. To learn more, see your John Deere dealer.

SERVICE

Sight gauges let you check hydraulic and drive system fluid levels quickly.



Bucket pins are oil-filled and sealed for virtually maintenance-free service and long life.

Bolt-on rod guides are easy to remove, should cylinder repair ever become necessary.



Five fin-per-inch radiator core provides efficient cooling, resists plugging, and cleans easily.

Lockable doors swing open wide to simplify fluid and filter checks, changes, and additions. Daily checks are accomplished on one side.



Lockable compartments on both sides of the cab provide plenty of space for storing a grease gun and tools.

Cab can be tilted in less than ten minutes for easier access to the hydrostatic drive motors and engine. Think of the savings that'll make on flat-rate repair costs.



Final drives incorporate a unique oil-filled double-seal design. If a failure occurs, the oil encased between the seals escapes, setting off an indicator light on the control panel. It's an early warning system that can help prevent major final-drive failures.

655C-II 755C-II



CONSTRUCTION EQUIPMENT

Engine	655C-II	755C-II
Type.....	Liebherr D 924 T-EA1 water-cooled and turbocharged diesel; Tier II emissions compliant	Liebherr D 926 T-EA2 water-cooled, turbocharged, and intercooled diesel; Tier II emissions compliant
Rated power.....	130 SAE net hp (97 kW) @ 2,000 rpm per ISO 9249	177 SAE net hp (132 kW) @ 1,800 rpm per DIN/ISO 3046
Cylinders (wet sleeve).....	4	6
Displacement.....	409 cu. in. (6.7 L)	610 cu. in. (10.0 L)
Fuel consumption, typical.....	3.2 to 5.5 gal./hr. (12 to 21 L/h)	4.2 to 7.4 gal./hr. (16 to 28 L/h)
Maximum net torque.....	450 lb.-ft. (610 Nm) @ 1,200 rpm	678 lb.-ft. (920 Nm) @ 1,000 rpm
Lubrication.....	pressure system with full-flow spin-on filter and integrated oil-to-water cooler	pressure system with full-flow spin-on filter and integrated oil-to-water cooler
Air cleaner.....	dual stage dry type with safety element and aspirated pre-cleaner, with dash-mounted restriction indicator	dual stage dry type with safety element and aspirated pre-cleaner, with dash-mounted restriction indicator
Electrical system.....	24 volt with 55-amp alternator	24 volt with 55-amp alternator
Cooling fan.....	blower-type, viscous drive	blower-type, viscous drive
Cold-starting aid.....	flame-glow intake air heater	flame-glow intake air heater

Transmission	655C-II / 755C-II
Dual-path, electronic-controlled, closed-loop hydrostatic drive; load-sensing feature automatically adjusts speed and power to match changing load conditions; each individual track is powered by a variable displacement pump and motor combination; single V-pattern lever controls speed and direction; ground speed (forward and reverse) infinite to 6.8 mph (11 km/h); decelerator pedal permits speed reduction from 6.8 mph (11 km/h) to holding; two working ranges; maximum speed-range control button located on dash; maximum speed in range is selected by F-N-R lever position	
Travel speeds (infinitely variable)	
Forward and reverse speed ranges	
Low speed range.....	0 to 4.0 mph (0 to 6.5 km/h)
High speed range.....	0 to 6.8 mph (0 to 11 km/h)

Final Drives
Heavy-duty double-reduction planetary final drives protected and integrated into the track roller frame with the hydraulic drive motor

Steering
Fully modulated, infinitely variable, pedal steering allows for full power turns and counterrotation; infinitely variable track speeds provide unlimited maneuverability and optimum control; hydrostatic steering eliminates steering clutches and brakes

Brakes
Hydrostatic (dynamic) braking stops the machine whenever the direction-control lever is moved to neutral or whenever the combined decelerator/brake pedal is fully depressed

Automatic Park Brake
Exclusive park brake feature engages wet, multiple-disc brakes whenever the engine stops, whenever the combined decelerator/brake pedal is fully depressed, whenever the park lock lever is placed in the start position, whenever the park brake button is pushed on the dash, whenever the F-N-R control is in the neutral position for more than seven seconds, or whenever machine motion is sensed with F-N-R in neutral position; machine cannot be driven with brake applied, reducing wear out or need for adjustment

Hydraulic System	655C-II	755C-II
System.....	load sensing	load sensing
Pressure, system relief.....	3,770 psi (26 000 kPa)	3,770 psi (26 000 kPa)
Pump type.....	variable-displacement piston pump with load-sensing proportional pump flow control	variable-displacement piston pump with load-sensing proportional pump flow control
Flow.....	41 gpm (156 L/min.) @ 2,100 rpm	55 gpm (209 L/min.) @ 1,900 rpm
Filter, return oil.....	20 micron and 5 micron with magnetic particle attractors	20 micron and 5 micron with magnetic particle attractors
Control.....	single joystick lever	single joystick lever
Cylinders.....	heat-treated, chrome-plated, polished cylinder rods with hardened steel pivot pins and replaceable bushings	heat-treated, chrome-plated, polished cylinder rods with hardened steel pivot pins and replaceable bushings
Hydraulic/transmission cooling.....	oil-to-air heater exchanger	oil-to-air heater exchanger
Loader cycle times		
Lifting.....	6.5 sec.	6.5 sec.
Lowering.....	2.1 sec.	2.1 sec.
Bucket dump.....	1.5 sec.	1.5 sec.

Capacities (U.S.)	655C-II	755C-II
Fuel tank with lockable cap (12-hr. typical usage).....	69 gal. (260 L)	84.5 gal. (320 L)
Cooling system with recovery tank.....	18 gal. (68 L)	15.3 gal. (58 L)
Engine oil including spin-on filter.....	5.3 gal. (20 L)	5.8 gal. (22 L)
Hydraulic/hydrostatic reservoir with filter.....	34 gal. (130 L)	46.2 gal. (175 L)
Splitter drive.....	2.6 qt. (2.5 L)	3 qt. (2.8 L)
Final drive (each).....	8.9 qt. (8.5 L)	18 qt. (17 L)

All power train and hydraulic systems allow for up to 45-degree maximum operation.

Undercarriage**655C-II****755C-II**

John Deere Dura-Trax™ features large deep-heat-treated components; pins and bushings are sealed for life; rollers and idlers are permanently sealed and lubricated; full-length track frame covers reduce material buildup and ease cleaning

Sprocket.....	segmented	segmented
Chain.....	sealed and lubricated	sealed and lubricated
Track shoes, each side.....	42	39
Ground contact area		
20-in. (508 mm) grouser width (closed		
center, double bar).....	3,902 sq. in. (25 180 cm ²)	4,210 sq. in. (27 160 cm ²)
22-in. (560 mm) grouser width (closed		
center, double bar).....	4,302 sq. in. (27 750 cm ²)	4,640 sq. in. (29 940 cm ²)
Ground clearance, minimum with double-bar		
grouser (excluding grouser height)	16 in. (395 mm)	17 in. (426 mm)
Length of track on ground	98 in. (2478 mm)	105 in. (2673 mm)
Track gauge, standard	66 in. (1680 mm)	71 in. (1800 mm)
Oscillation at front idler	4.5 in. (114 mm)	5 in. (127 mm)
Track rollers, each side	6	6
Carrier rollers, each side	1	1
Track pitch.....	6.9 in. (175 mm)	8 in. (203 mm)

Ground Pressures

With standard equipment, cab, bucket, full fuel tank, and 175-lb. (79 kg) operator		
Standard bucket with bolt-on teeth		
With 20-in. (508 mm) double-grouser shoes.....	8.7 psi (60 kPa)	11.0 psi (76 kPa)
With 22-in. (560 mm) double-grouser shoes.....	7.9 psi (54 kPa)	10.0 psi (69 kPa)
Multipurpose bucket with bolt-on teeth		
With 20-in. (508 mm) double-grouser shoes.....	9.0 psi (62 kPa)	11.3 psi (78 kPa)
With 22-in. (560 mm) double-grouser shoes.....	8.2 psi (57 kPa)	10.3 psi (71 kPa)

SAE Operating Weights

With standard equipment, cab, standard bucket, full fuel tank, 175-lb. (79 kg) operator, and 20-in. (508 mm) double-grouser shoes.....	33,950 lb. (15 400 kg)	46,300 lb. (21 000 kg)
--	------------------------	------------------------

Optional or Special Equipment

<i>Add (+) or deduct (-) lb. (kg) as indicated to base weight for units with</i>		
20-in. (508 mm) track shoes.....	included in base	included in base
22-in. (560 mm) track shoes.....	220 lb. (100 kg)	309 lb. (140 kg)
Additional front lights (2)	26 lb. (12 kg)	26 lb. (12 kg)
Bolt-on rock guards.....	320 lb. (145 kg)	558 lb. (253 kg)
Bottom tank guards.....	783 lb. (355 kg)	915 lb. (415 kg)
Heavy-duty grille guard	207 lb. (94 kg)	245 lb. (111 kg)
Heavy-duty extended rear bumper†	322 lb. (146 kg)	322 lb. (146 kg)
Hydraulic controls for front attachment.....	121 lb. (55 kg)	126 lb. (57 kg)
Hydraulic controls for rear attachment.....	132 lb. (60 kg)	132 lb. (60 kg)
Lower counterweight*.....	N/A	2,205 lb. (1000 kg)*
Multipurpose bucket with bolt-on teeth	1,190 lb. (540 kg)	1,288 lb. (584 kg)
Rear counterweight*	550 lb. (250 kg)	550 lb. (250 kg)
ROPS canopy (less cab).....	- 419 lb. (- 190 kg)	- 419 lb. (- 190 kg)
Segmented cutting edges.....	176 lb. (80 kg)	254 lb. (115 kg)
Three-shank radial ripper	see ripper data, page 15	see ripper data, page 15

*Included in base.

†Recommend removal of 550-lb. (250 kg) rear counterweight.

655C / 755C SERIES II LOADERS WITH STANDARD BUCKETS

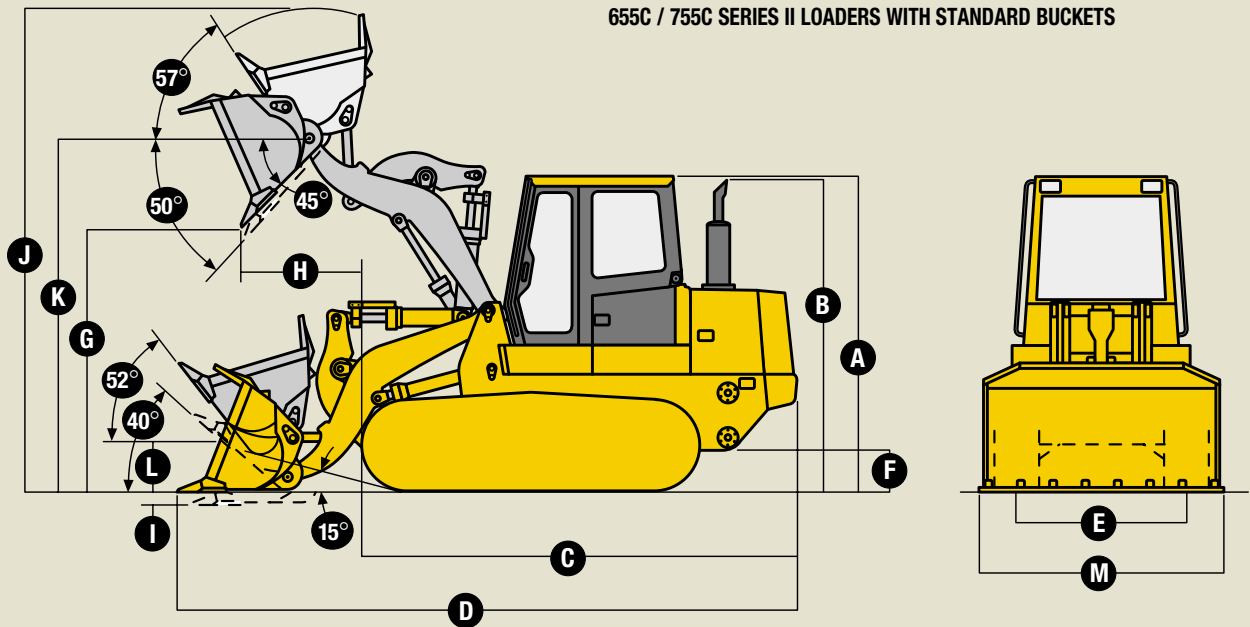

Dimensions

655C-II

755C-II

Rounded to the nearest whole number.

A Height over cab (including grousers)	123 in. (3129 mm)	130 in. (3304 mm)
B Height over exhaust pipe.....	122 in. (3092 mm)	125 in. (3186 mm)
C Length to front of track	171 in. (4339 mm)	189 in. (4801 mm)
D Overall length (with bucket).....	241 in. (6132 mm)	269 in. (6832 mm)
E Track gauge.....	66 in. (1680 mm)	71 in. (1800 mm)
F Ground clearance.....	15.6 in. (395 mm)	16.8 in. (426 mm)

Standard Bucket with Bolt-on Teeth

Capacity heaped (ISO 7546)	2.35 cu. yd. (1.8 m ³)	3.14 cu. yd. (2.4 m ³)
Breakout force	27,675 lb. (12 550 kg)	37,080 lb. (16 820 kg)
Static tipping load	23,086 lb. (10 470 kg)	30,418 lb. (13 795 kg)
G Dumping height at 45 degrees.....	111 in. (2827 mm)	121 in. (3085 mm)
H Reach at 45 degrees.....	42 in. (1072 mm)	47 in. (1192 mm)
I Maximum digging depth below grade	5.2 in. (132 mm)	5.6 in. (142 mm)
J Maximum operating height.....	197 in. (5000 mm)	217 in. (5505 mm)
K Maximum height of hinge pin.....	144 in. (3662 mm)	159 in. (4040 mm)
L Height of hinge pin, transport position.....	20 in. (503 mm)	23 in. (573 mm)
M Width of bucket.....	96 in. (2445 mm)	98 in. (2500 mm)

**655C / 755C SERIES II LOADERS WITH MULTIPURPOSE BUCKETS AND
THREE-SHANK RIGID-TYPE RADIAL RIPPER WITH ESCO RIPPER TIPS**

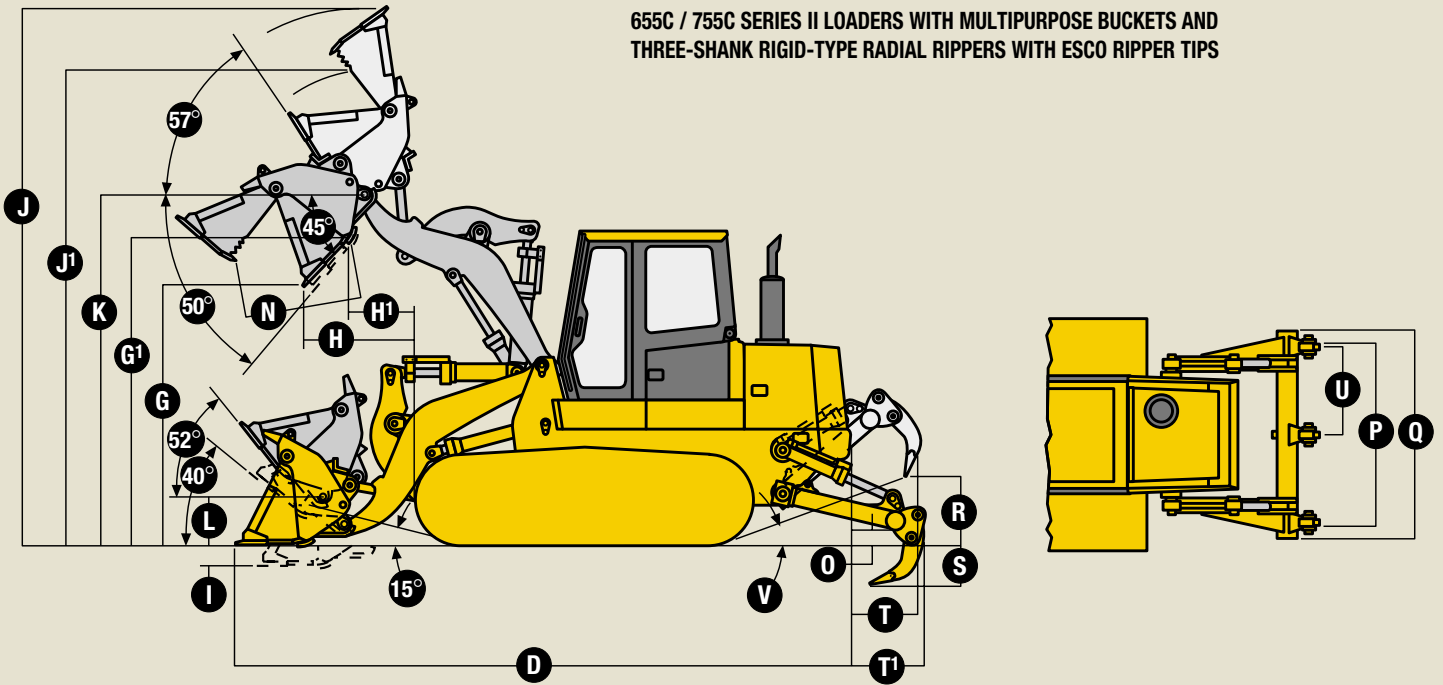

**Multipurpose Bucket
with Bolt-on Teeth**

	655C-II	755C-II
Capacity heaped (ISO 7546).....	2.1 cu. yd. (1.6 m ³)	2.6 cu. yd. (2.0 m ³)
Breakout force	24,525 lb. (11 120 kg)	35,283 lb. (16 000 kg)
Static tipping load	21,226 lb. (9628 kg)	27,684 lb. (12 555 kg)
Maximum clamping force.....	19,147 lb. (8680 kg)	22,473 lb. (10 190 kg)
D Overall length (with bucket).....	247 in. (6275 mm)	273 in. (6938 mm)
G Dumping height at 45 degrees – bucket	107 in. (2716 mm)	118 in. (2997 mm)
G¹ Dumping height at 45 degrees – blade	128 in. (3252 mm)	141 in. (3574 mm)
H Reach at 45 degrees – bucket	44 in. (1114 mm)	46 in. (1180 mm)
H¹ Reach at 45 degrees – blade	25 in. (629 mm)	26 in. (656 mm)
I Maximum digging depth below grade	7.1 in. (180 mm)	8.3 in. (212 mm)
J Maximum operating height – bucket open	217 in. (5509 mm)	238 in. (6044 mm)
J¹ Maximum operating height – bucket closed.....	193 in. (4896 mm)	214 in. (5424 mm)
K Maximum height of hinge pin.....	144 in. (3662 mm)	159 in. (4040 mm)
L Height of hinge pin, transport position.....	20 in. (503 mm)	22 in. (567 mm)
M Width of bucket.....	96 in. (2445 mm)	98 in. (2500 mm)
N Width of opening.....	48 in. (1215 mm)	51 in. (1285 mm)

Three-Shank Rigid-Type Radial Ripper with ESCO Ripper Tips

Weight	1,742 lb. (790 kg)*	2,359 lb. (1070 kg)**
O Ground clearance below toolbar	6.5 in. (166 mm)	7.9 in. (200 mm)
P Ripping width.....	69 in. (1760 mm)	73 in. (1860 mm)
Q Toolbar width.....	79 in. (1996 mm)	83 in. (2100 mm)
R Lifting height.....	28 in. (712 mm)	30 in. (771 mm)
S Ripping depth.....	14 in. (352 mm)	15 in. (385 mm)
T Additional overall length – raised	27 in. (676 mm)	26 in. (660 mm)
T¹ Additional overall length – lowered	29 in. (729 mm)	25 in. (635 mm)
U Distance between teeth.....	33 in. (850 mm)	35 in. (900 mm)
V Angle	21 degrees	21 degrees

*When mounting the 655C ripper, the rear 550-lb. (250 kg) counterweight must be removed. Net machine weight change is 1,215 lb. (541 kg).

**When mounting the 755C ripper, the rear 550-lb. (250 kg) and underside 2,205-lb. (1000 kg) counterweights must be removed. Net machine weight change is – 157 lb. (– 71 kg).

655C / 755C Series II Loaders

Key: ● Standard equipment ▲ Optional or special equipment

*See your John Deere dealer for further information.

655 755 Engine

- 130-hp (97 kW) Liebherr D 924 T-EA1 water-cooled, turbocharged 4-cylinder diesel (EPA Tier II emissions compliant)
- 177-hp (132 kW) Liebherr D 926 T-EA2 water-cooled, turbocharged, and inter-cooled 6-cylinder diesel (EPA Tier II emissions compliant)
- Blower-type cooling fan with viscous drive off gear-driven water pump
- Dual-element dry-type aspirated air cleaner with automatic dust ejector
- Electric fuel pump
- Enclosed secondary fan guard (conforms to SAE J1308)
- Engine coolant to -34°F (-37°C)
- Fuel system with prefilter, water separator, and microfilters
- Quick-release fuel filter
- Heavy-duty five-fin-per-in. radiator
- Intake air heater cold-starting aid
- Under-hood muffler with vertical exhaust stack
- Oil-to-water engine oil cooler
- Pressure lubrication for operation up to 45 degrees
- Spin-on full-flow oil filter, with anti-drain back valve
- Starter motor, 7.2 hp (5.4 kW)
- Starter motor, 8.9 hp (6.6 kW)
- Turbocharger provides spark arresting

Power Train

- Dual-path hydrostatic transmission: Dynamic braking / Electronically controlled with power management and AutoTrac / Infinite speed control / Pedal steer with full power turn and counter-rotation / V-pattern F-N-R control
- Automatic spring-applied, hydraulic released parking brake
- Hydraulic/transmission oil-to-air cooler, independent of radiator with hydrostatically driven cooling fan
- Park brake button: Neutralizes transmission and activates parking brake
- Pedal-operated secondary service brakes
- Transmission system diagnostic test ports
- Two-speed transmission maximum speed control with dash-mounted indicator light

Electrical

- 24-volt system
- Alternator, 55 amp
- Batteries (2), heavy-duty cold start, 760 CCA
- Batteries (2), heavy-duty cold start, 1,050 CCA
- Positive battery terminal covers
- Electrically activated battery master disconnect
- Fuse-protected circuits
- Working lights, cab mounted, front (2) and rear (2)
- ▲ Additional front lights (2)
- ▲ Light guarding*

655 755 Hydraulic System

- 41-gpm (156 L/min.) load-sensing variable-displacement pump
- 55-gpm (209 L/min.) load-sensing variable-displacement pump
- Boom float with on/off indicator light
- Circuit relief valve protection
- Electrical switches for lift stop, bucket positioning, and bucket float
- Electrically controlled bucket float
- Hydraulic functions disabled with park lock lever
- Hydraulic/hydrostatic oil reservoir with sight glass
- Hydraulic system diagnostic test port
- "O"-ring seal connectors
- Replaceable filter, 20/5 micron with magnetic particle attractors
- Single V-pattern lever control
- Tank shutoff valves for service
- Two-function loader valve with single-lever bucket control
- ▲ Hydraulic controls for front and rear attachments

Undercarriage

- 66-in. (1680 mm) gauge standard track frame
- 71-in. (1800 mm) gauge standard track frame
- Center track guides
- Front idler and sprocket chain guides
- Full-length track frame covers
- Hydraulic track adjusters with hinged dirt cover
- Oscillating track frames
- Isolation-mounted pivot shafts and equalizer bar
- Maintenance-free track components, sealed and lubricated rollers, idlers, and sprockets
- Sealed and lubricated track chain
- Segmented bolt-on sprockets
- ▲ 20-in. (508 mm) closed-center double-bar track grouser shoes
- ▲ 22-in. (560 mm) closed-center double-bar grouser shoes
- ▲ Full-length bolt-on rock guards

Operator's Station

- Modular cab with integrated ROPS/FOPS (conforms to SAE J1040, ISO 3471/3449): Hydraulically tilted / Isolation mounted / Air conditioner/heater/defroster/pressurizer with filtered fresh air intake and two-speed blower / Ashtray / Dome light / Fabric seat cushions / Lockable doors (open and closed position) / Pull-down sunshade / Radio-installation provision / Rearview mirror / Sliding side windows / Tinted glass / Windshield wipers, front and rear, with washers
- ▲ Modular ROPS/FOPS canopy, isolation mounted, vinyl seat cushions (conforms to SAE J1040, ISO 3471/3449)

655 755 Operator's Station (continued)

- Left and right access
- Built-in operator's manual storage compartment and operator's manual
- Rubber floor mat
- Deluxe mechanical suspension seat: Adjustable armrests, backrest, height/weight, and fore-aft / Seat cushion tilt
- ▲ Deluxe air suspension power-adjustable seat (cab only): Adjustable armrests, backrest, height/weight, and fore-aft / Fabric seat cushions / Seat cushion tilt
- Seat belt, 2-in. (50 mm), retractable (conforms to SAE J386)
- ▲ Seat belt, 3-in. (76 mm), retractable with CRS (conforms to SAE J386)*
- Electronic monitor system with audible and visual warnings: Engine air filter restriction / Hydraulic/hydrostatic filter restriction / Hydrostatic transmission pressure / Low alternator voltage / Park brake
- Gauges, electric, illuminated: Engine coolant temperature / Engine oil pressure / Fuel / Hourmeter
- Horn, electric
- Key start switch with electric fuel shutoff
- 24-volt power port
- Lever-controlled throttle
- Slip-resistant steps and ergonomically located handholds
- ▲ Radio AM/FM*

Attachments

- General-purpose bucket with bolt-on teeth and back-drag rear edges
 - ▲ Multipurpose bucket with bolt-on teeth
 - ▲ Cutting edge segments, reversible*
 - ▲ Three-shank radial ripper
- ### Overall Vehicle
- 66.0-gal. (250 L) fuel tank with wide-mouth filler cap
 - 84.5-gal. (320 L) fuel tank with wide-mouth filler cap
 - Bucket-level indicator
 - Hinged reinforced radiator guard
 - Loader boom service lock
 - Lockable vandal protection: Battery compartment / Engine access doors / Fuel tank / Hydraulic and transmission access door / Instrument panel (canopy only) / Storage compartments (2)
 - Oil-lubricated lower bucket pins
 - One-piece unitized mainframe
 - Rear drawbar hitch with pin
 - Reinforced engine bottom guards
 - Return-to-dig feature
 - Reverse warning alarm (conforms to SAE J994, J1446)
 - Tool kit with brake-release towing kit
 - Z-bar bucket linkage
 - ▲ Bumper, heavy-duty extended rear*
 - ▲ Grille, heavy-duty horizontal louvered*
 - ▲ Lifting lugs*



JOHN DEERE

Net engine power is with standard equipment including air cleaner, exhaust system, alternator, and cooling fan, at standard conditions per SAE J1349 and DIN 6270B, using No. 2-D fuel at 35 API gravity. No derating is required up to 10,000 ft. (3050 m) altitude for both the 655C-II and 755C-II.

Specifications and design subject to change without notice. Wherever applicable, specifications are in accordance with SAE standards. Except where otherwise noted, these specifications are based on units with standard equipment, 20-in. (mm) track grouser shoes, modular cabs with air conditioning, full fuel tanks, and 175-lb. (79 kg) operators; 655C unit with 2.35-cu. yd. (1.8 m³) bucket; and 755C unit with 3.14-cu. yd. (2.4 m³) bucket.

